

S-1100

The Speedy Interior S-1100 with wand control self-aligning vertical track system provides the safety of a cord free, tangle free, traversing and rotating blind for standard commercial installations, while offering an economical maintenance free product.

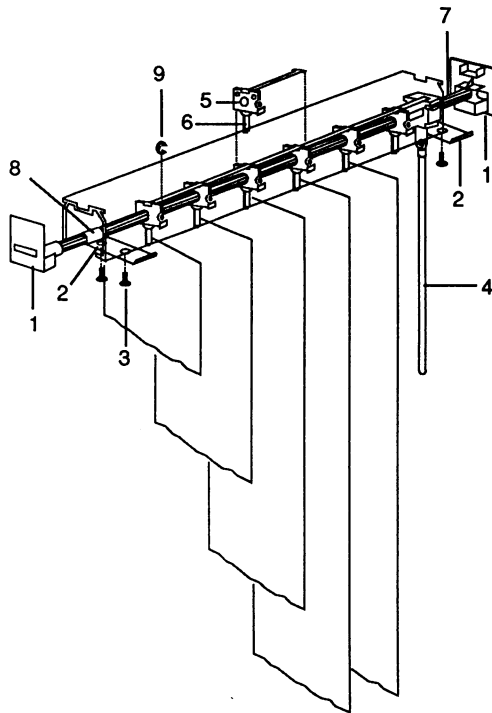

- | | |
|-----------------|-----------------------|
| 1. Idle End | 6. Hanger w/Gear Stem |
| 2. Curve Bar | 7. Pinion Rod |
| 3. Screws | 8. Spacer |
| 4. Wand Control | 9. "C" Clip, 8 prong |
| 5. Carrier Body | |

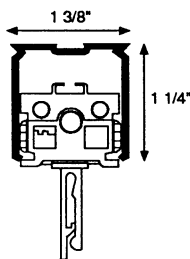

One half scale cutaway view of carrier truck

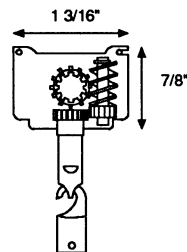

One half scale cutaway view of wand control

SPECIFICATIONS:

GENERAL: S-1100 self-aligning, traversing and rotating headrail system is manufactured by Speedy Interior, 3562 Eastham Drive, Culver CA 90230

STACK: Available in one way draw (left or right).

TRAVERSING: Vertical blinds shall traverse left to right or right to left. Blinds shall traverse by means of a wand control.

WHEELS: Each louver carrier shall traverse on self-lubricating wheels to reduce draw force. No glides or sliders shall be allowed.

ROTATION: A 24" or 48" wand provides 180 degree rotation to each vane simultaneously through a gear system in the control housing. This drives an 8 prong extruded aluminum pinion rod which passes through all the vane carriers providing rotation to each vane through a precision molded rack and pinion gear system. Louvers shall be held in a fixed position until reset.

CHANNEL: Headrail channel shall be of anodized aluminum alloy 1³/₈" wide by 1¹/₄" high with .032 inch minimum wall thickness or roll-formed steel 1¹/₂" wide by 1¹/₄" high with .025 inch minimum wall thickness. The headrail will extend the width of the blind. The channel is available in baked enamel ivory and white.

END CONTROLS: Each headrail channel shall be equipped with two idle end controls made of high quality Delrin resin made by Dupont or equivalent.

CARRIERS: Each carrier is made of high quality Delrin resin made by Dupont or equivalent. The shaft walls of the carrier are made of reinforced plastic for strength. The vane stem shall be replaceable on site without demounting the track and shall be centered, allowing the track to be reversible. Louvers shall rotate 180 degrees by an 8 prong pinion rod.

SPACING: Visually uniform vane spacing is achieved by means of a spacer arm integrally molded with the carrier body and adjustment clips. Normal spacing is a minimum of 3/8" less than the louver width.

MAXIMUM SIZE RECOMMENDATIONS:
 Maximum width: 156"
 Maximum drop: 120"
 Louver width: 3¹/₂"

WARRANTY: Speedy Interior carries a lifetime warranty against defects in materials or workmanship.



SPEEDY INTERIOR
 1630 W. 132nd St., Unit B
 Gardena, CA 90249

Telephone (310) 768-0333
 Telephone (800) 677-5588
 Facsimile (310) 768-0363

Contractor's Lic. # 743930